

# EASYWALL INSTALLATION GUIDE

A STEP-BY-STEP GUIDE TO INSTALLING YOUR FENCE





# INTRODUCTION

Thank you for choosing Fentec EasyWall range. This product will provide you with many years of trouble free protection if installed in accordance with the directions outlined in this document.

The recommendations detailed in this guide are formulated along the lines of good building practice. They are not intended to be an exhaustive statement of all the relevant data.

If you have any questions, please contact our Technical Team on 0800 002 725. We are always happy to help in any way we can.

## BEFORE YOU START, READ THIS

- ✓ This guide does not apply to any fences over 1.8m in height. If your fence is greater than 1.8m, please seek further advice from Fentec.
- ✓ Describe your site details when ordering materials.
- ✓ Identify your soil type/ground conditions. Refer to the table in Step 1. This will determine the concrete and footing details required.
- ✓ Make sure you are aware of underground services before you start digging! These could be gas, electricity, or water mains. Call your local council for more information.
- ✓ Check your local council regulations on boundary fencing.
- ✓ Check the delivered material for the correct number of components and general condition before beginning your installation.

## TOOLS LIST

- Make sure you choose the right tools before start installing your fence.

### TOOLS

- Tape Measure
- Spade
- Shovel
- Level
- String Line
- Concrete

### OPTIONAL

- Auger - 300mm diameter
- Hacksaw or powered metal cutting saw
- Laser-level

### SAFETY GEAR

minimum required

- Safety Boots
- Gloves
- Helmet
- Eye Protection
- Hearing Protection
- Sun Protection



It is recommended that the reader pays particular attention to those items identified as IMPORTANT in this manual to ensure satisfactory long-term performance.

# A STEP-BY-STEP GUIDE TO INSTALLATION

## STEP 1 - MARKING OUT POST HOLES

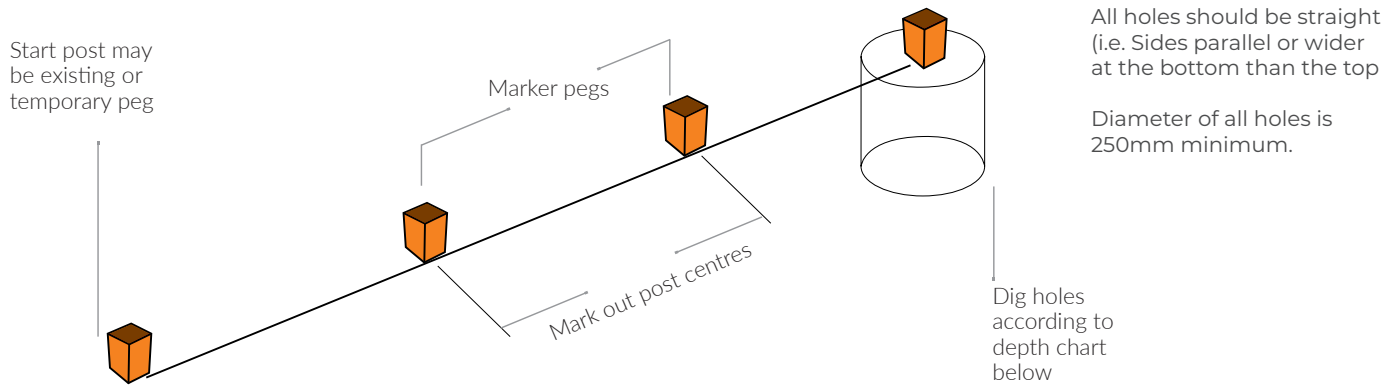

Soil Type	Minimum Hole Depth	Approximate Concrete Required
Clay / Firm Earth	600mm	2 bags per hole (20Kg bag)
Sand / Loose Fill	900mm	3 bags per hole (20Kg bag)

## STEP 2 - INSTALLING POSTS

### 2.1 Fastening posts together

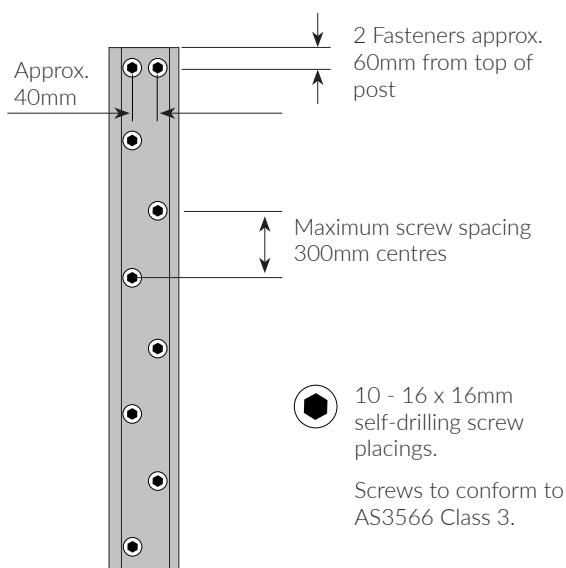

If it isn't possible to fix posts as proposed here, please contact us for further information.

### 2.2 Fixing posts in ground

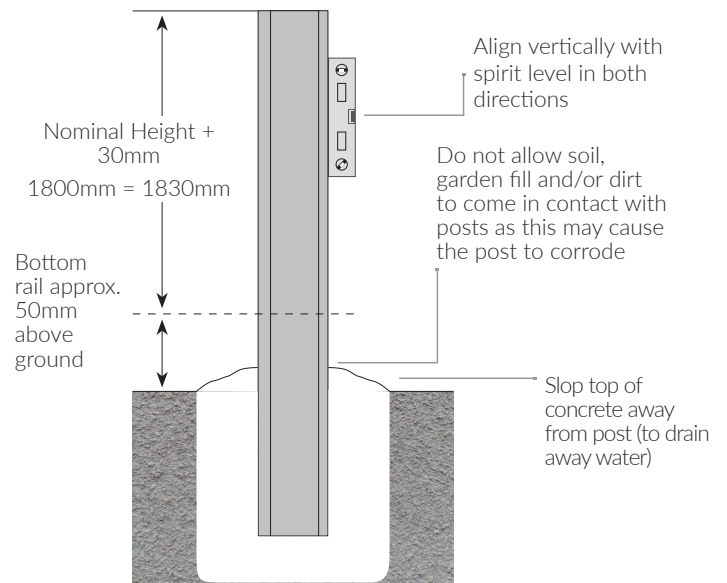

- Place first post in hole
- Adjust to correct height
- Support post with temporary brace
- Fill hole with fully mixed, wet concrete
- Vibrate and compact the concrete to remove voids.

## STEP 3 - INSTALLING RAILS | INSTALLING PALINGS

### 3.1 Bottom Rail

- Insert bottom rail between posts.
- Adjust bottom rail to correct height - it is important to maintain a minimum gap of 50mm between bottom of rail and ground.
- Screw fix the bottom rail at this stage.

**NOTE:** EasyWall Vertical fence system is supplied with a Rail Support and this is to be inserted inside the bottom rail prior to it being installed.

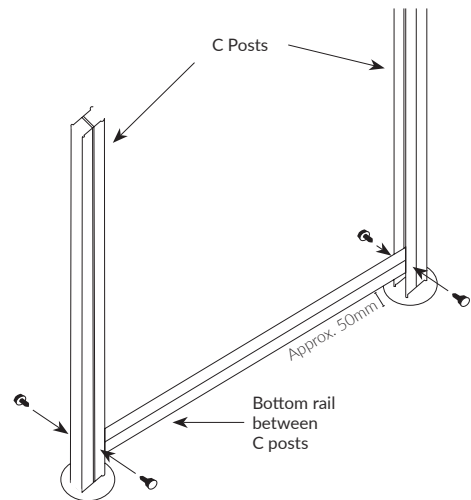

### 3.2 Palings

For **EasyWall Vertical**

- Slide the first paling into the bottom rail with the groove in end of paling to the bottom.
- Ensure a 15mm gap is between the edge of paling and the inside face of the post and push down firmly into the bottom rail. A rubber mallet can be used if required.
- Continue to insert all palings, ensuring the tongue and groove joint is in place correctly.
- Once all palings are installed it is time to fit your top rail.

### 3.3 Top Rail

- Place over the top of the palings, and tap down into the C post. Once in place, fix both sides of the rail to the C post using the tech screws provided. The top of the rail should be 15mm from the top of the post.

### 3.4 Check Installation

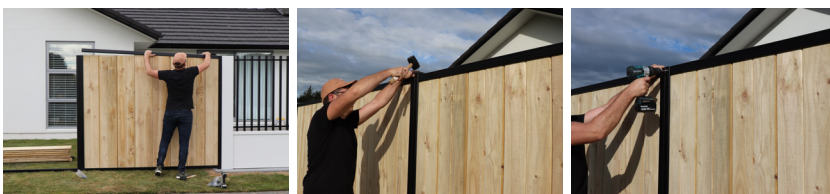

For **EasyWall Horizontal**

- Slide the first paling into the bottom rail with the tongue in edge of paling to the top.
- Ensure a 15mm gap is between the end of paling and the inside face of the post and push down firmly into the bottom rail. A rubber mallet can be used if required.
- Continue to insert all palings, ensuring the tongue and groove joints are in place correctly.
- Once all palings are installed it is time to fit your top rail.

**NOTE:** when building a 1800h horizontal fence the 7th (top) paling is to be cut down in width to suit total height needed.

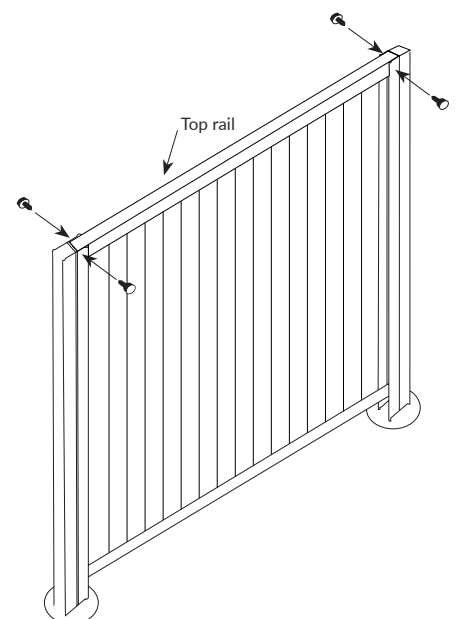

## STEP 4 - INSTALLING POSTS CAPS

- ✓ All EasyWall caps are supplied as a 'double' cap, which are designed to be snapped in half to create two single caps where required.

- 4.1** Cut each side of the cap in line with the centre ridge. Use end-nippers – do not use a knife as this is dangerous and difficult to achieve a straight cut.

Ensure the 'nose' of the end nippers is pushed all the way in before cutting.



- 4.2** Bend the cap along the centre ridge to snap it, and pull apart to create two single caps.



**NOTE:** If the cap is not a tight fit, place a small amount of silicone up inside the cap to secure it. Make sure the silicone is a small bead on the inside corner of the sides only.

**IMPORTANT** ■ ■ ■ Make sure you keep the correct distance from the top of the post to the top of the rail (see page 4).

### MAINTENANCE OF YOUR FENCE

- To keep your fence looking its best, a soft broom down every few months should be sufficient to remove any cobwebs. Pay particular attention to the area under the top rail, which is sheltered from natural washing by rain.
- DO NOT** build up soil, garden fill and/or dirt against the bottom rails and posts of your fence as this will retain water and lead to corrosion.  
**DO NOT** use your fence as a retaining wall, as it is not designed for this purpose.
- Adequate drainage is needed to ensure that water does not pond in the bottom rail. This is achieved by designing the posts such that there is a clearance between the ends of the bottom rail and the posts.
- DO NOT** use touch up paint. Minor scratches should be left alone or the post/rail replaced. Touch up paint will weather differently than the original steel coating. A small touch up brush can be supplied for any small scratches.
- The steel posts and rails are backed by a 10-year warranty\* under the following conditions:
  - Installation > 1km from Marine or Industrial environment
  - Fence is installed to manufactures guidelines
  - Fence is maintained regularly in accordance with suggestions made by Boundaryline.

There is no warranty on the timber components due to being a natural product.



## CONTACT FENTEC

FENTEC'S TECHNICAL SUPPORT: 0800 002 725

TO LEARN MORE VISIT: [WWW.FENTEC.CO.NZ](http://WWW.FENTEC.CO.NZ)

This document is only intended to be a general guide, as every property and situation is different. Any installation work, including the use of power equipment is completely the responsibility of the person(s) installing. All persons using power equipment must be trained and certified to use the equipment and must wear all applicable personal protection gear. Fentec cannot accept any responsibility for any faulty installation or damage or injury arising from installation work.



0800 002 725 | [fentec.co.nz](http://fentec.co.nz)