

SlatWall

Installation Guide



A step-by-step guide to installing your fence

Introduction

Thank you for choosing Fentec SlatWall Fencing. This product will provide you with many years of trouble free protection if installed in accordance with the directions outlined in this document.

The recommendations detailed in this guide are formulated along the lines of good building practice. They are not intended to be an exhaustive statement of all the relevant data.

If you have any questions, please contact our Technical Team on 0800 002 725. We are always happy to help in any way we can.

Before you start, read this

This guide does not apply to any fence over 1.8m in height. If your fence is greater than 1.8m, please seek further advice from Fentec.

Describe your site details when ordering materials.

Identify your soil type/ground conditions. Refer to the table in Step 1. This will determine the concrete and footing details required.

Make sure you are aware of underground services

before you start digging! These could be gas, electricity, or water mains. Contact your local council for more information.

Check your local council regulations on boundary fencing.

Check the delivered material for the correct number of components and general condition before beginning your installation.

Tool List

Make sure you choose the right tools before you start your fence.

Tools

- Tape measure
- Square
- Shovel
- Line marking paint
- String line
- Spirit or laser-level

- Hex drive bit
- Angle grinder
- Drill/driver
- Post hole digger
- Circular saw

Safety Gear (minimum required)

- Safety boots
- Gloves
- Helmet
- Eye protection
- Hearing protection
- Sun protection

It is recommended that the reader pays particular attention to those items identified as **Important** in this manual to ensure satisfactory long-term performance.

Components List

Slotted Post Insert

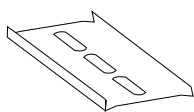

Notched SlatWall

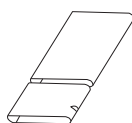

Locking Plug

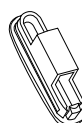

Grommet



Angle



Post Caps

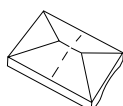

C Posts

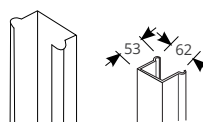

Rails

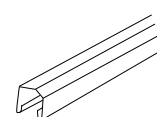



Standard SlatWall panels are 2380mm wide which is also the standard length for Fentec rails. The slat length is determined by subtracting 40mm from the distance between your posts; e.g. 2380mm panel will require 2340mm slat length.

Important:

Please ensure that the posts are installed no more than 2380mm (+10mm) apart.

Items required for one panel (2380mm)

- Fentec Standard C Posts and Universal Rails (x2 each).
- Fentec Caps (x2).
- Self-drilling screws Hex Head #10-16 (pre-painted) for joining posts to rails (see table below for quantity).
- Wafer Head screw 10g 40mm GAL for securing Centre Vertical Slat (x2).  
- One Slotted Post Insert pack (choose size) includes: one Slotted Post Insert pre-fitted with CNF-UP3 Grommets and One Slotted Post Insert pre-fitted with CNF-UP4 Locking Plugs.
- Notched SlatWall steel slats (see table below for quantity).
- SlatWall steel Centre Vertical Slat - pre-drilled including one pack of matching 4/5 aluminium rivets. Quantity equals 1 per slat.
- Angle (300mm fence topper only - to attach Centre Vertical Slat to base of rail).

Fence Height (mm)	1800	1480	1163	300	1800
Slat Spacing (mm)	25	25	25	25	15
SlatWall Steel Slat Quantity	21	17	13	3	23
Slat Length (mm)	2340	2340	2340	2340	2340
Slotted Post Inserts (mm) (x2)	1690	1373	1053	250	1690
Centre Vertical Slat (mm) (x1)	1790	1470	1153	300	1790
Aluminium Rivets 4-5	21	17	13	3	23
Self-drilling Wafer head screw #10-16 (x40)	2	2	2	2	2
SlatWall Post** (mm) (x2)	2400	1800	1800	n/a	2400
SlatWall Rail (mm) (x2)	2380	2380	2380	2380	2380
Hex Washer Head pre-painted #10-16 screw (x16)	24	20	18	n/a	24

**Post size is dependent on whether the posts are installed in the ground or on a concrete slab.

Post Installation

Step 1 > Mark out your post holes

All holes should be straight i.e. sides parallel or wider at the bottom than the top.

Diameter of all holes is 200mm minimum.

Start post may be existing or temporary peg.

Marker pegs. Mark out post centres = bottom rail length + 10mm (typical dimensions may be 2380 to 2390mm)

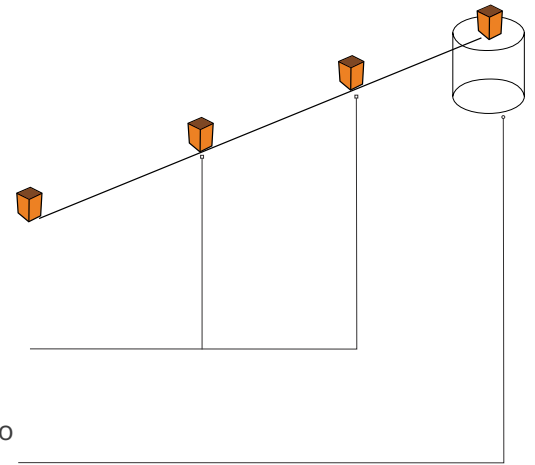

Dig holes according to depth chart below

Important: Table A: Post lengths required will increase accordingly to cater for these ground conditions.

Soil Type	Minimum Hole Depth	Approximate Concrete Required
Rock	300mm	1 bag per hole (20Kg bag)
Clay/Firm Earth	600mm	2 bag per hole (20Kg bags)
Sand/Loose Fill	900mm	3 bag per hole (20Kg bags)

Step 2 > Securing posts

a. Fastening posts together

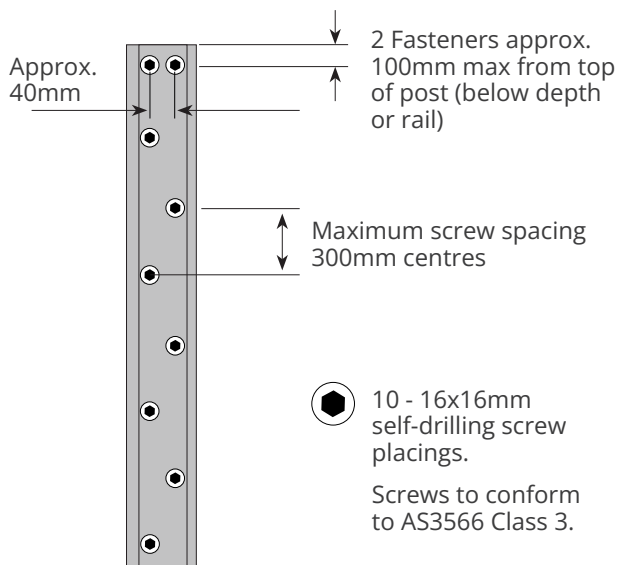

b. Fixing post in ground

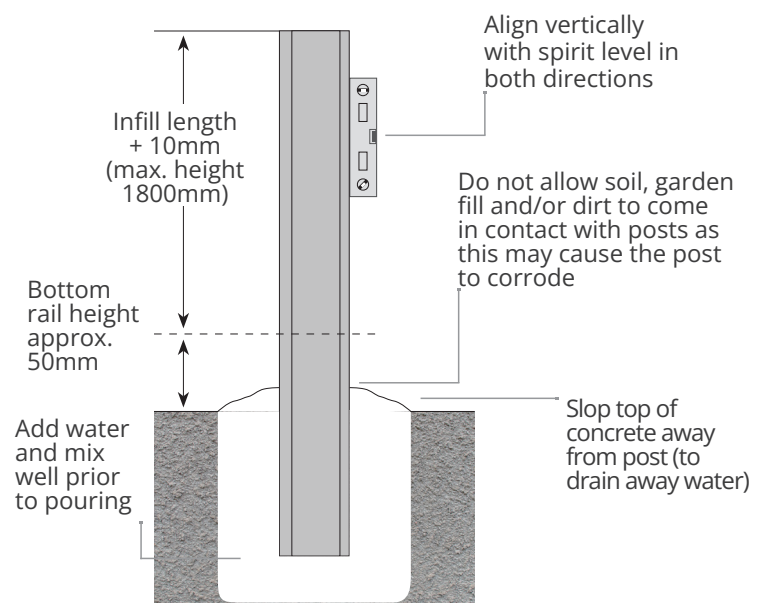

Important:

If it isn't possible to fix posts as proposed here, please contact us for further information.

1. Place first post in hole.
2. Adjust to correct height - see step 3 to determine height.
3. Support post with temporary brace.
4. Fill hole with fully mixed, wet concrete.
5. Vibrate and compact the concrete to remove voids.

Typical installation option for end posts, corner posts & junctions

□ - 65mm SHS Section □ - Fence Post

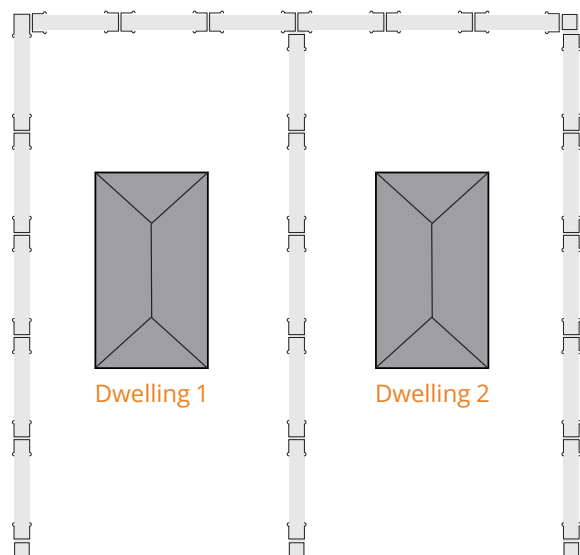
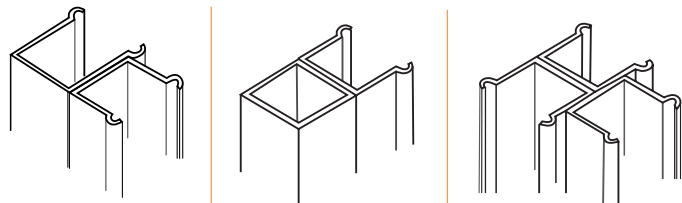
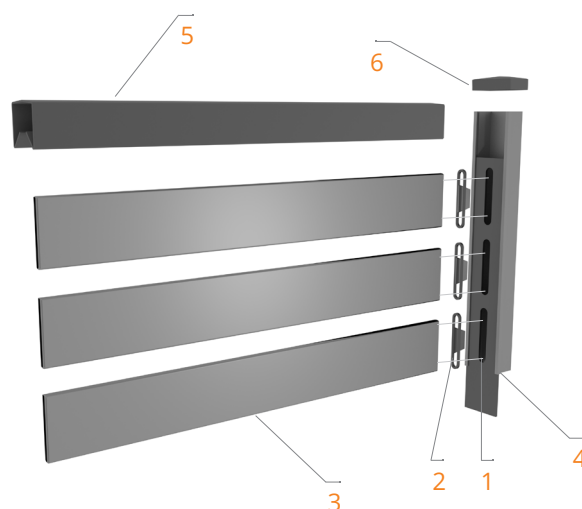

Table B: Components

Item	Part Number	Description
1	SPI-xx	Slotted Post Insert
2	UNI3	Grommet
3	NMS-xx	Notched SlatWall
4	Post-xx	Standard C Post
5	Rail-xx	Universal Rail
6	Cap-xx	Post Cap



You can choose to leave off the double caps for the C Post to be flush with the finishing rails.

Step 3 > Rail installation

Insert bottom rail (item 5) between posts to determine the exact location of next post. It is important to maintain a gap of 50mm between bottom of rail and the ground.

With the bottom rail (item 5), the slotted post insert (item 1) and the top rail (item 5) in place, the C post (item 4) should be sitting proud at the top by approx 15mm. This allows enough room for your plastic cap to be fitted off later.

The slotted post insert (item 1) can be inserted into the C post (item 4) to determine the overall fixing position for the rail (item 5). Fix off bottom rail with the provided tek screws.

Step 4 > Slotted post inserts

- Ensure locking plugs and grommets are fully seated into the slotted post inserts. CNF-UH4 locking plugs go into one post insert and CNF-UP3 grommets go in the other post insert. Make sure the locking plugs are all the same with the lock point at the bottom of the slot.
- Remove top rail and insert slotted post inserts with locking mechanism of the plug at the base or bottom of each hole. If you are facing the fence, the locking plug with the fully enclosed backing will be in the left-hand post. You are now ready to insert the slats.

Step 5 > Inserting the slats

- Pull back the core strip (plastic covering) from each end of the slat approximately 100mm. Each slat will have a small notch near the bottom of the left end.
- The slat's roll-formed seam should be at the top rear of the slat when it is inserted.
- Insert the slat into the top hole of the slotted post insert by pushing it fully into the UP3 grommet until it contacts the rear of the SlatWall post. The other end of the slat will now be able to be pushed into the UP4 locking plug where it is pushed into the final locking position. You may need to move the slat up or down to get it past the edge of the SlatWall post.
- Continue installing the slats until all slots are filled.
- Peel all plastic core strip from the installed slats and discard.
- Mark the centre of the top and bottom slats with a non-carbon pencil.
- Peel the corestrip (plastic covering) from the Centre Vertical Slat (CVS) just before use. The pre-drilled CVS is now placed in position by standing it in the centre of the bottom rail and moving it into position with the slats. The CVS is then riveted into position using the pre-drilled holes.
- Replace the top rail on the fence panel and secure with pre-painted self-drilling hex. Head screws #10-16. One screw each side of each corner i.e. 8 per panel.
- Secure the CVS to the top and bottom rails using a 10G 40mm wafer head screw.

Important:

Always start at the top as you may injure your fingers starting from the base if a slat slips and falls next to an inserted slat.

Step 6 > Installing post caps

All SlatWall caps are supplied as a 'double' cap, which are designed to be snapped in half to create two single caps where required. Please note - only black double caps are available.

1



Cut each side of the cap in line with the centre ridge. Use end-nippers – do not use a knife as this is dangerous and difficult to achieve a straight cut. Ensure the 'nose' of the end nippers is pushed all the way in before cutting.

2



Bend the cap along the centre ridge to snap it, and pull apart to create two single caps.

Notes:

If the cap is not a tight fit, place a small amount of silicone up inside the cap to secure it. Make sure the silicone is a small bead on the inside corner of the sides only.

Maintenance of Your Fence

1. To keep your fence looking its best, simply wash down periodically with water when cleaning the car or watering the garden. A soft broom should be sufficient to remove any cobwebs. Pay particular attention to the area under the top rail, which is sheltered from natural washing by rain.

2. **DO NOT** build up soil, garden fill and/or dirt against the bottom rails and posts of your fence as this will retain water and lead to corrosion. **DO NOT** use your fence as a retaining wall, as it is not designed for this purpose.

3. Avoid spraying the fence with garden sprays or fertilisers as these can damage the surface. If this occurs wash the fence down with water.

Adequate drainage is needed to ensure that water does not pond in the bottom rail and to assist in the

removal of debris. This is achieved by ensuring there is a clearance between ends of the bottom rail and the inside of the posts.

4. **DO NOT SPRAY** touch up paint directly onto fence as it weather differently to the SlatWall steel. Recommended practice is to spray paint into the inside of the can lid and then touch up any small scratches with a small brush limiting the paint that's applied to the sheet to the scratched area only.

5. Fencing is backed by a 10-year warranty* under the following conditions:

- Installation > 1km from marine or industrial environment
- Fence is installed to manufactures guidelines
- Fence is maintained regularly in accordance with suggestions made by Fentec.

SlatWall Fencing is designed to withstand most wind conditions. The wind on the fence at your site will depend on a number of factors, including the number of surrounding properties and how exposed the location is.

If your property is exposed to higher wind speeds, please contact us for further advice/recommendations.

Also, if in proximity to severe marine conditions or bounding swimming pools, please seek specific advice from Fentec.

This document is only intended to be a general guide, as every property & situation is different. Any installation work, including the use of power equipment is completely the responsibility of the person(s) installing. All persons using power equipment must be trained & certified to use the equipment & must wear all applicable personal protection gear. Terranota Ltd cannot accept any responsibility for any faulty installation or damage or injury arising from installation work.



fentec.co.nz | 0800 002 725
sales@fentec.co.nz

